

LED

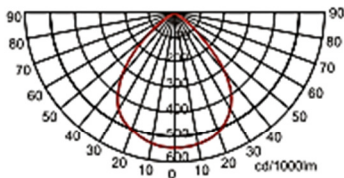

Ex Code: Ex d IIC T6/T5
 Standard: GB3836.1, GB3836.2
 IEC60079-1:2007,MOD

Light distribution curve



Floodlight

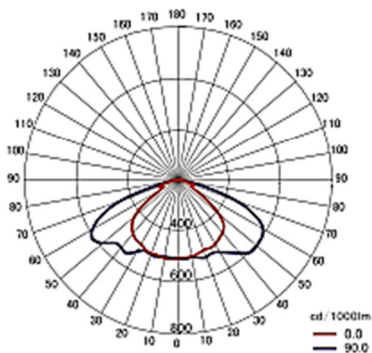

Streetlight

Application

- Ideal to be used in the oilfield, chemical industry, steel industry, power, port, Petroleum etc.
- Harsh environment, moist area.
- Gas explosive environment : Group IIA, IIB, IIC
- Zone 1, Zone2; Zone 21, Zone 22
- Temperature class: T1 to T6

Characteristics

- Adopts America BridgeLux LED light source, can save 60% on energy than metal halide lamp.
- The blade-shape housing and heat sink on back cover ensure the lamp to efficiently dissipate heat so that prolong LED life.
- Taiwan Meanwell LED driver, power factor >0.98, more stable performance.
- Adjustable position-locking device on the bracket can tightly fix the lamp to any desired angle, keep the lamp from moving in harsh vibration area.
- The anti corrosion aluminum alloy body is powder coated, anti corrosion, dust proof, water proof. Suitable to be used in harsh environment.
- Flame proof type of protection, safe for use in all kinds of inflammable and explosive area.
- The lamp can parallel connected , no need to use the junction box.
- Flame proof type of protection, safe for use in all kinds of inflammable and explosive area.
- The lamp can parallel connected , no need to use the junction box.
- Beam angle: 90° (standard), 60° , 120° and streetlight beam angle is optional.

Technical Specification

Input Voltage	90-305VAC / 127-431VDC
Output Voltage	36VDC
Frequency	50Hz / 60Hz
Anti corrosion grade	WF2
Insulation Grade	I
Screw Thread	G3/4"
Cable Diameter	φ 8mm- φ 14mm
Dimension	φ 300x202x332mm
Net Weight	6.3Kg

Drawing of dimension (Dimensions in mm)

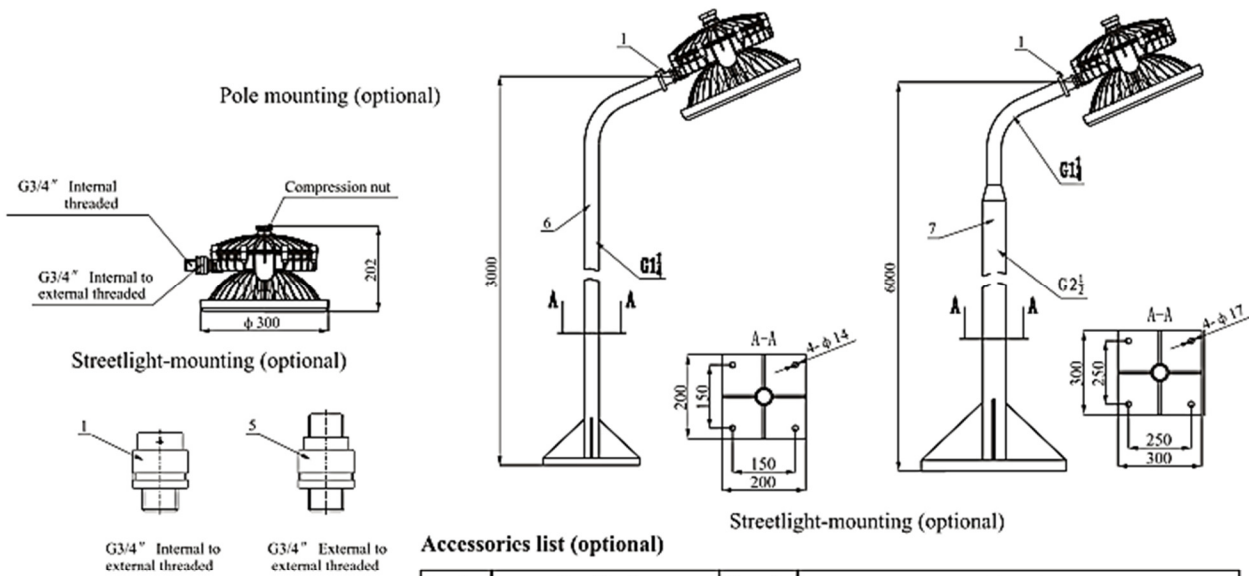
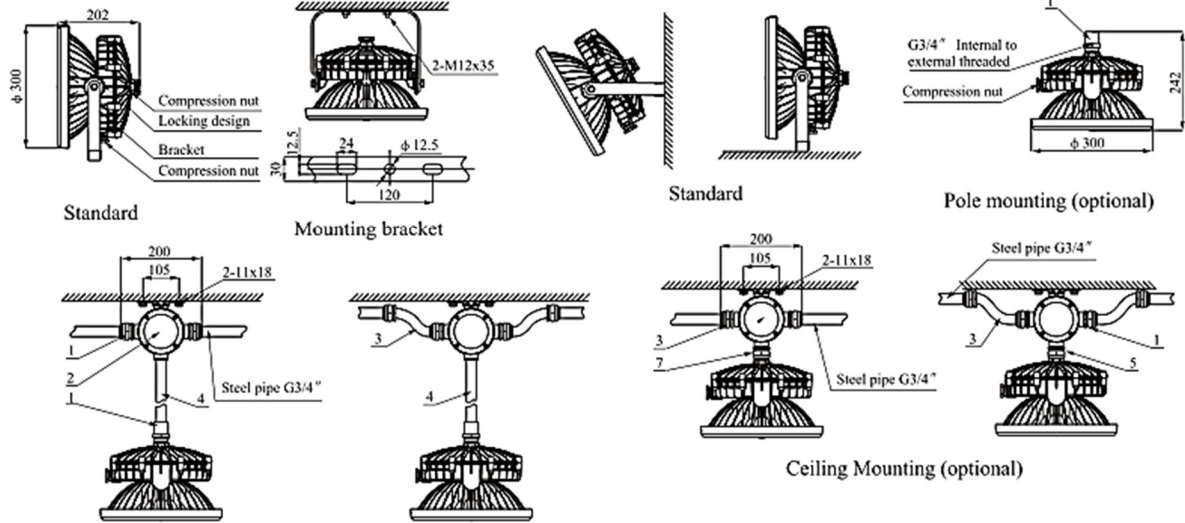

Accessories list (optional)

Number	Specification	Quantity	Remark
1	Explosion proof connector	1	G3/4" Internal to external
2	Explosion proof junction box	1	G3/4"
3	Connecting pipe	2	G3/4" Internal to external
4	G3/4" pole	1	The length in accordance with the request of the customer
5	Explosion proof connector	1	G3/4" external to external
6	Flange mounted type pole	1	3 meters
7	Street light pole	1	6 meters



BC9700 – LED Explosion Proof Light

Ordering reference

Model Number	Light Source	Rated wattage (W)	Light output (lm)	Temperature Class	Equivalent to		
					Metal halide lamp	Induction lamp	Mercury lamp
BC9700-L50	LED	50	6,100	T6	100W	100W	125W
BC9700-L60	LED	60	7,250	T6	150W	135W	175W
BC9700-L80	LED	80	9,880	T6	175W	165W	250W
BC9700-L100	LED	100	11,200	T6	250W	200W	250-400W
BC9700-L120	LED	120	14,000	T5	250-400W	250W	400W